

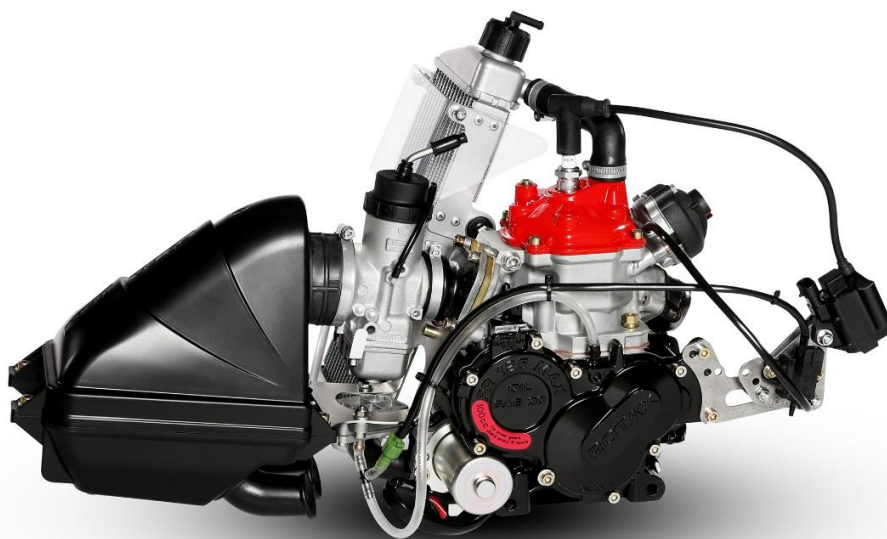

BNL KARTING SERIES

TECNICAL REGULATIONS 2018

SENIOR MAX



Approved by RACB/.... Visa number

Technical Regulations EVO MAX SENIOR

4.0 / Chassis	Maximum one chassis per event (weekend). Only CIK/FIA homologated chassis after 2006 are allowed. The homologation sheet has to be available at any time.		
4.01 / Brakesystem	Only hydraulic, CIK/FIA homologated brakes are allowed. The homologation sheet has to be available at any time. Front brakes are not allowed. Between the master brake cylinder and the brake pedal an extra security brake cable is mandatory. Minimum 1,8mm thickness. Also an extra security clip is mandatory at the brakepads. A ceramic brake disc is not allowed.		
4.02 / Rear axle			
Diameter	Ø40mm of Ø50mm magnetic material, in a whole.		
Wall thickness	(40mm) minimum 2,9mm / (50mm) minimum 1,9mm (entire length.)		
4.03 / Rims	Aluminium or magnesium/diameter 5 inch		
Dry	Maximum 135/215mm / measured to the outside of the rim		
Rain	Maximum 130/180mm +/- 5mm / measured to the outside of the rim		
Rear width	Maximum 140cm / measured to the outside of the rim Minimum : see 4.05 "rear bumper"		
	Any additions to the rims are not allowed. Except : adhesive balancing lead. Beat retaining screws are mandatory.		
4.04 / Tyres			
Slicks	MOJO D5	Front : 4,5x10x5	Rear : 7,1x11x5
Rain	MOJO W3	Front : 4,5x10x5	Rear : 6,0x11x5
	<p>Slick race tyres must be ordered in advance through the organisation by means of a voucher (see sporting regulations).</p> <p>Two sets of tyres are allowed for each meeting. It is allowed to mix the tyres during the event.</p> <p>Tires must be mounted according to the direction of rotation defined on the tire.</p> <p>It is not allowed to modify the tyres. The brand name, code number, barcode and the indications always need to be visible on the tyres. Only normal air is allowed to fill the tyres.</p>		
4.05 / Rear bumper/ Front bumper	The plastic rear bumper must be CIK homologated and cover at least 2/3 of the rear wheels, and may not protrude the rear tyres. Only a CIK homologated clickable front bumper is allowed.		
4.06 / Side-pods Frontspoiler for steering column	Only a complete CIK homologated spoiler set is allowed. The complete spoiler set should have the same homologation number. The homologation sheet has to be available at any time.		

4.07 / Fueltank	The plastic fuel tank should be mounted in a correct way, at the appropriate place. All vents must culminate in a reservoir
4.08 / Age	15 years or older (ór reach the age of 15 in 2018)
4.09 / Weights and clothing	<p>Minimum 165 kg at each moment of the event A driver must be equipped and appear for inspection with the following gear: (see time table)</p> <p style="padding-left: 40px;">Complete equipment must comply with the CIK regulations</p> <p style="padding-left: 40px;">A turbo visor is allowed in case of rain</p> <p style="padding-left: 40px;">Gloves which cover the entire hand</p> <p style="padding-left: 40px;">High shoes that cover and protect the ankles.</p> <p style="padding-left: 40px;">The responsible doctor on the event may, for safety reasons, disapprove certain types of breast, neck or rib protections.</p> <p style="padding-left: 40px;">A neck protection is not required yet recommended</p> <p>From the moment when the driver goes on track, he must wear the mandatory race gear as described in this article.</p>
4.10 / Starting numbers	Yellow plate with black digits. (Range 201 - 299) (Front, rear, left and right sides)
4.11 / Seat	<p>The seat has to be fixed at minimum 4 places, 2 at the top (left and right) and 2 on the bottom (left and right)</p> <p>All seat supports have to be fixed with washers with a minimum thickness of 1,5mm and a diameter of 40mm</p>
4.12 / Lead	<p>Drivers who are lighter than the required minimum weight shall attach extra weight on their kart, until they reach the prescribed weight. Lead may only be installed on the chassis or on the seat. The Technical Scrutineering can force each driver to mount the lead on another place.</p> <p>The lead shall be mounted so that everyone's security is guaranteed at all times:</p> <ul style="list-style-type: none"> • Up to 3kg: at least with 2x M6 bolts • Up to 6kg: at least with 2x M8 bolts • Up to 10kg: at least 4x M8 bolts
4.13 / Data Systems	<p>Data logging with or without a GPS module is allowed. Data from the GPS module may only be saved systems which has been mounted on the kart.</p> <p>Every other form of telemetry or radio communication is not allowed. Transferring data during sessions to a device, other than the data logger on board is not allowed.</p> <p>Power to activate the data system should be taken from a separate battery. It is not allowed to take power from the battery that is used for the engine.</p>
4.14 / Cameras	Drivers may use a camera if mounted in an appropriate way and accepted by the Scrutineers. Helmet cameras are not allowed. Clips, etc, for mounting a camera may not be fit on the helmet.

Engine – Rotax EVO MAX Senior

4.15 /
Foreword

These regulations will be valid as of 1st of February 2018 and will replace all previous regulations. Only originals spare parts which are manufactured by Rotax BRP are legal to be used.
Any modifications are not allowed.
Eventually helix reparations with heli coils and/o wire bushes are allowed.

4.16 /
Engines

Each race-meeting its allowed to enter two engines. The engines should be sealed with an official Rotax seal. The engine registration card has to be available at any time.

4.17 /
Squish

Minimum 1,00mm (including possible carbon deposits)

Measuring

Engine temperature below 30 degrees Celcius.
The squish gap must be measured with a certified slide gauge and by using a 2 mm tin wire (Rotax part no. 580 130).

The crankshaft must be turned by hand slowly over top dead centre to squeeze the tin wire.

The squish gap must be measured on the left and right side in the direction of the piston pin.

The average value of the two measurements counts.

4.18 /
Combustion chamber
insert

Cast identification code has to be "223 389" or "223 389 1" or "223 389 2" or 223 389 2/1" or "223 389 2/2".
Casted wording "ROTAX" and/or "MADE IN AUSTRIA" must be shown.



Height of the combustion chamber insert has to be **27,55mm, (+0,0/-0,1mm)(A)** and **28,80mm ± 0,2mm (B)**

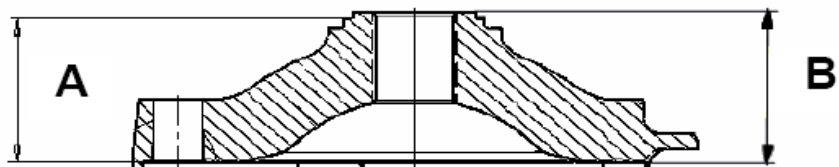

The profile of the combustion chamber insert has to be checked with a template (ROTAX part no. 277390). The crack of light between the template and the profile of the combustion chamber insert has to be the same over the whole profile.



4.19 /
Cylinder head

It is allowed to change the colour of the cilinderhead cover for indentification.

4.20 /
Piston with ring
assembly

Original, coated, aluminium, cast piston with one piston ring. The piston has to show on the inside the cast wording "ELKO" (1) and "MADE IN AUSTRIA" (2)

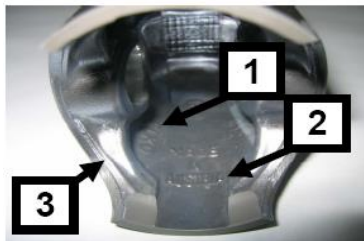

Machined areas are: Top end of piston, outside diameter, groove for the piston ring, bore for the piston pin, inside diameter at bottom end of piston and some pre-existing factory removal (3) of flashing at the cut out of the piston skirt.

All other surfaces are not machined and have cast surface.

Any mechanical treatment or rework of the piston is forbidden, (e.g. removal of carbon deposits).

Cleaning without changing the original surface is allowed.

Original, magnetic, rectangular piston ring.

Ring height : 0,98 +/- 0,02 mm.

Piston ring is marked either with "Rotax 215 547", "Rotax 215 548" or **Rotax 215 548X**

The piston ring is legal also if just parts of the marking are still visible.



4.21 /
Piston pin

Piston pin is made out of magnetic steel. Dimensions must be according to the drawing. The minimum weight of the piston pin must not be lower than : 32,10 grams

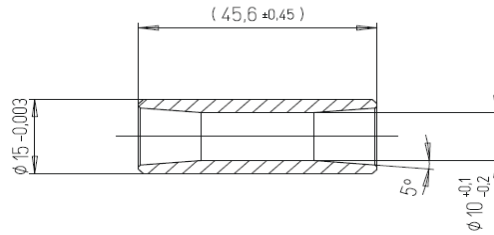

4.22 /
Cylinder

Cylinder with one main exhaust port and exhaust valve. Cylinders marked (cast or machined) with identification code 223 993 and 613372 + Rotax logo only are legal to be used.



Cylinder types >2018, partnr : 223993 marked with the letter "V" into the inlet port are also allowed.

The upper edge of the central boost port may show factory machining. See pictures below

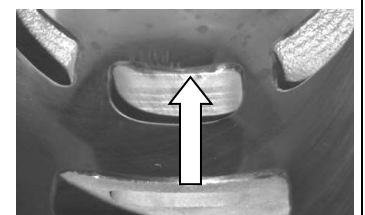
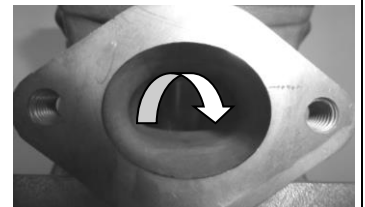

Light-alloy-cylinder with GILNISIL plating. Type Senior with power-valve. Cylinder with one head exhaust port.

Replating or modification is not allowed.

4.23 /
Maximum bore

54,035mm (measured 10mm above the exhaust port)

4.24 /
Cylinder measures

Height of cylinder should be 87mm (-0,05 / + 0,10mm)



Exhaust port timing

The "exhaust port timing" (distance from the top of the cylinder to the top of the exhaust port) has to be checked by means of the template (ROTAX part no. 277 402).

Insert the template for Senior Max cylinder into the cylinder, and move the template (at the highest point of the exhaust port) as far as possible into the exhaust port.

In this position the template may not touch the cylinder wall

Any modification is strictly forbidden!

The horizontal and vertical dimensions of the exhaust port (cylinder 223 994 with fully CNC machined exhaust port only) have to be checked with the template (Rotax part no. 676 240).

The horizontal and vertical dimensions of the exhaust port (cylinder 223 993 with fully CNC machined exhaust port only) have to be checked with the template (Rotax part no. 676 245). The template has to be moved in horizontal - and vertical position as far as possible into the exhaust port. In both directions the template may not touch the exhaust socket flange

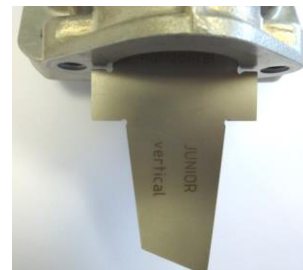

All transfer ports and passages have cast finish surface except some removal (done by the manufacturer) of cast burr at the inlet passage, exhaust port and passages. All ports have chamfered edges to prevent ring snagging. Any additional machining is not permitted. The top edge of exhaust port may show some pre-existing machining from the manufacturer. The sealing flange for the exhaust socket may show signs of machining from the manufacturer. All ports have chamfered edges. Any additional machining is not permitted.

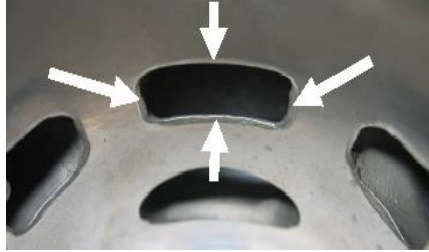

Cylinders with code 613372 the upper edge of the central boost may show factory machining. See picture.

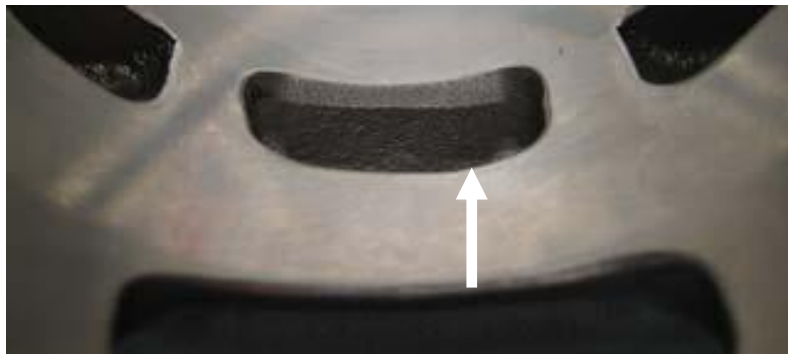

The top edge of the exhaust port may show either just a cast finish surface or signs of a CNC machining or sign of CNC machining in combination with sign of manual grinding.



The flange for the exhaust socket may show either cast finish or machined surface. Machined surface can be either flat or show a circular sealing bump.

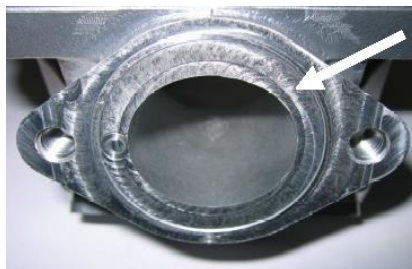

4.25 /
Power valve

Electronic timed system must be used only. System has to be used with all components fitted as shown in the illustration below. Only green coloured exhaust below (item 10) (Rotax nr 260723) is legal to be used. The original compression spring has to be used.

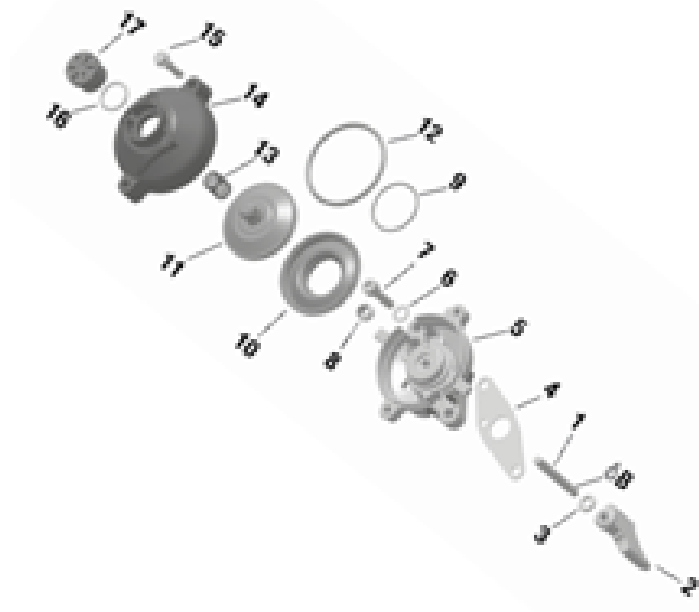

Fitting an original impulse nozzle (1) into the pressure hose in an allowed adjustment. The direction of the impulse nozzle inside the pressure hose is free.



Length of the exhaust valve : $36,50\text{mm} + 0,20 / -0,30\text{mm}$ (see picture)
Width of collar $4,80\text{mm} \pm 0,30\text{mm}$ (see picture)
Any modification is not allowed.

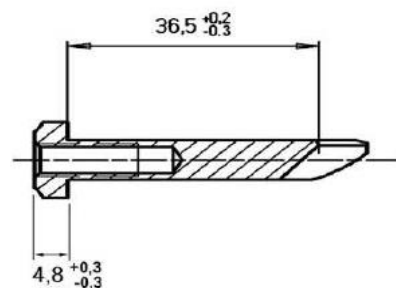

If the piston closes the exhaust port totally it has to be able to put a special template (Rotax nr. 277 030) into the power valve port.

This template must be at all times fully connected to the cylinder surface. It should not be possible to put a filler gauge of 0.05mm between.



Only the original gasket between cylinder and power valve house is allowed. Modifications are not allowed.

**4.26 /
Inlet system**

The inlet manifold is marked with the identification code 267915 or 267916

Some factory flash removal may be present at the conjunction of the inside contour and the carburettor stop mounting face. No additional grinding or machining is permitted.



The reed valve assembly is equipped with 2 petal stops and 2 reeds, each having 3 petals. The thickness of the reeds is 0,60 mm +/- 0,10mm. Modification is not allowed.

**4.27 /
Con rod**

Stroke: 54,5mm ± 0,1mm
Con rod has to show forged numbers "367" or "362"
(see pictures)



Shafts of con rods are not machined. Grinding or polishing of shaft of con rod is not permitted.

Crankshaft

Crankshaft has to be unprocessed and may not be damaged.

Ignition signal on crankshaft :

Fit the template (Rotax 277391) on the crankshaft. Align the hole in the template for the big end pin with the big end pin of the crankshaft. The two edges of the signal machining on the crankshaft must be in line ($\pm 0,5\text{mm}$) with the corresponding edges (MAX) of the template.



4.28 / Balance shaft / drive

Balance shaft and balance gears must be installed.
Configuration of part (Rotax nr. 237 949) only is legal.

Surface (1) is not machined and must show cast surface. Measurement from centre of balance shaft to outer diameter of fly weight of balance shaft at defined length must not be lower than specified : (21,50mm) see drawing.

The minimum weight of the dry balance shaft must not be lower than: 255 gram for balance shaft. (Rotax nr. 237 949)

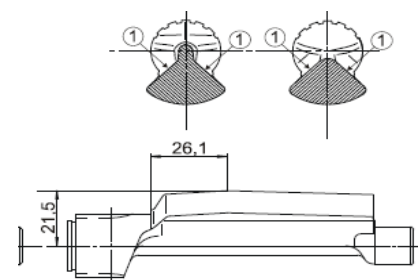

Balance drive

Balance gears must be installed and must be aligned according to the instruction in the repair manual.

Latest steel balance gears (Rotax nr/ 234435 or 234436) in combination with the new clutch is allowed.

Mixing the two types of balance gears is not allowed!

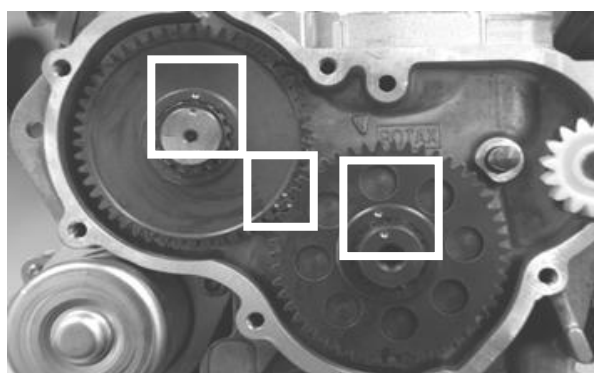

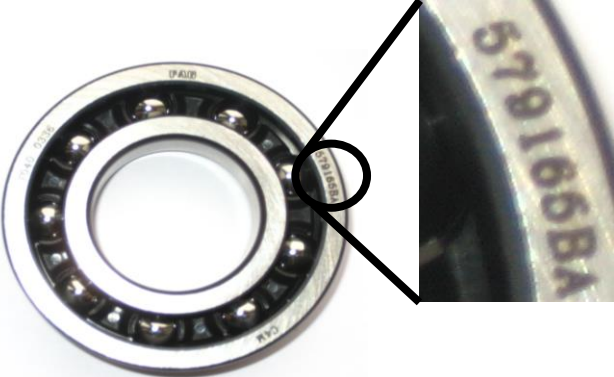
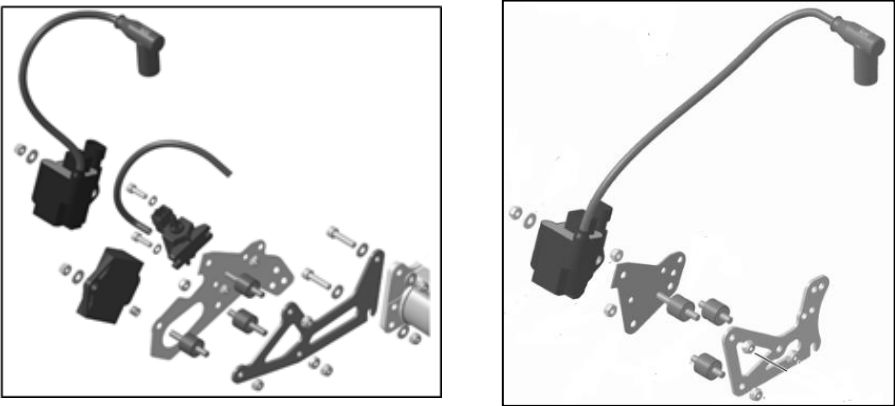
<p>4.29 / Crankcase</p>	<p>As supplied by the manufacturer. No grinding/polishing is permitted in the two main transfer passages as well as in the crank area. Uncoated as well as black coated crankcases are legal to be used.</p>
<p>4.30 / Crankshaft main bearings</p>	<p>Crankshaft main bearing 6206 from FAG is allowed only. The bearings must be marked with 579165BA or Z-579165.11.KL (see picture)</p> 
<p>4.31 / Ignition system</p>	<p>Senior EVO Dellorto ignition system. Ignition coil with separate electronic ECU box (Rotax nr. 666815). The ECU box is still legal to be used if the sticker is removed.</p> <p>Ignition coil and ECU box and magnet valve have to be fitted with all components according to the illustrations below :</p>  <p>In case the mounting bracket is in conflict with a chassis component, the additions of 2 spaces, one per mounting hole, with a maximum thickness of 20mm between the mounting bracket and the gearbox cover is allowed. Two different mounting versions (left illustrations and right illustration) are legal.</p> <p>At the mounting version as shown in the left illustration, the ground cable of the cable harness has to be connected to the lower rubber buffer of the support plate. Removing the black coating of the gearbox in specific areas, for mass connection between cable harness and engine, is a legal modification.</p>

The visual appearance of the ignition coil must be identical with the pictures below.



Ignition coil must show two pins at the terminal. The ignition coil is labelled with two stickers : "BRP 666820" and "NIG 0105". The ignition coil is still legal to be used if one or both stickers disappeared.

The minimum length of the high tension cable of the ignition coil is 210mm (from outlet of ignition coil to outlet of spark plug connector = visible length of cable)

The organization reserves the right at all times to exchange ignitions coils and / or ECU boxes with ignition coils and or ECU boxes from other drivers or organization.

The ECU box can be checked with the ECU box tester (Rotax nr. 276230)

Start the test by pressing the button . After approx. 3 seconds the type of ECU box that is actually testes will be indicated in the second line of the display. After approx. 30 seconds the result of the test will be indicated in the first line of the display.

The ECU box tester has to indicate following results:

125 MAX category

1. 666815MAX
2. !! Test OK !!

The marking of the pick-up must show the following numbers in the first line : 029600-0710 followed by a variable production serial number.



Additional gasket, Rotax 431 500, gasket thickness = 0,8 mm
Maximum two gaskets (Rotax 431 500) are allowed to be fitted.

4.32 /
Sparkplug / Caps

Following spark plugs are legal to be used :
NGK GR8DI / NGK GR9DI

Maximum spark plug shaft including ring : 18,00mm.

Two versions of spark plug caps are legal to be used :

Version 1. Black, marked with "NGK TB05EMA"
Version 2. Red, marked with "NGK"

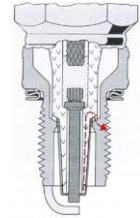

4.33 / Battery

Original batteries with following specifications are legal to be used :

- Rotax type RX7-12B
- Rotax type RX7-12L (lithium iron phosphate type)
- YUASA YT7B-BS

Specifications of the batteries should be readable at all times.

Battery must be fitted with the original battery clamp and battery cover (pictures below) and must be fixed to the chassis with both clamps (4 screws). Battery clamp must be mounted on the left side of the seat.

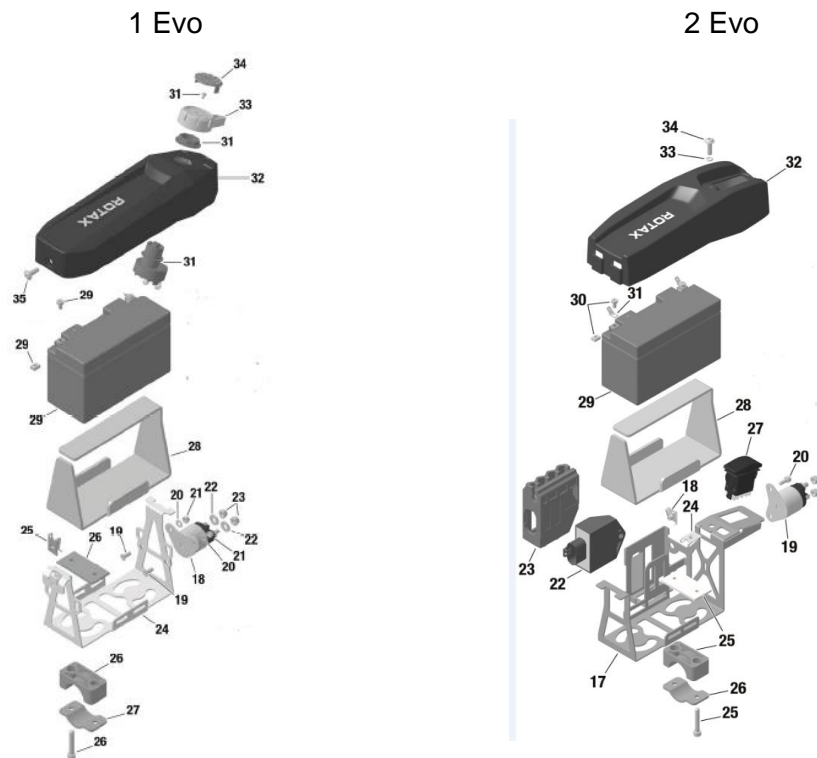

Only original plugs from the Rotax wiring harness are legal to connected to the battery.

4.34 /
Carburetor

DELLORTO Type VHSB 34. Housing has to show the cast wording "VHSB 34". Carburettor housing is stamped with "XS".

The complete inlet bore of the carburettor must show cast surface.
Carburettor slide shows digits "45" in casting

Following specifications:

- Carburettor venturi insert 12,5.
- Needle jet stamped with "DP267".
- Jet needle stamped with "K57".
- Start jet stamped with "60".
- Idle jet stamped with "60".
- Idle emulsion tube stamped with "45".
- Float lever according template (Rotax nr. 277400.)
- Floats marked "4,0 gr" are legal to be used only.
- Needle valve assembly stamped "150". Needle of needle valve marked with diamond symbol "INC" only.
- All jets must be correctly seated and securely fitted at any time (tightened)!
- Settings of the carburettor adjustment screws (idle and idle air) are free.
- Settings of main jets is free.
- Optional carburettor plug (Rotax nr. 261030) is legal to be used.

Only original Dellorto parts are legal to be used. Even if not supplied by Rotax.

See checklist DELLORTO for further info.

4.35 /
Fuel pump

MIKUNI fuel pump, type DF 44-210 is mandatory. Fuel pump must be mounted on the bottom side of the support bracket for the intake silencer.

4.36 /
Fuel filter

It is **not mandatory** to mount a fuel filter, but if a fuel filter is mounted only the version showed in the picture below is allowed :



Except the fuel line, the fuel pump and the original fuel filter no additional parts are legal to be mounted between the fuel tank and carburettor.

4.37 /
Radiator

The removal of the thermostat from the cylinder head cover is an allowed modification. Radiator must be mounted with all components.

Any tape is not allowed. It is an allowed modification to use a plastic plate/flap to control the air flow through the radiator. Any other non-original device to control the air flow through the radiator is prohibited.

The radiator has to be mounted on the right side of the engine. The following version is legal to be used :

Rotaxnr. 295928 (version 3, with original or without cooling flap)

Cooling area :
Height: 290mm
Width: 138mm
Thickness of radiator : 34mm



4.38 /
Engine coolant

Plain water without any additives has to be used.
The venting of the radiator should end in a reservoir.

4.39 /
Clutch

Engagement speed of centrifugal clutch at maximum 4.000rpm (the kart without driver must start to move).

Latest clutch version with steels balancing gears.

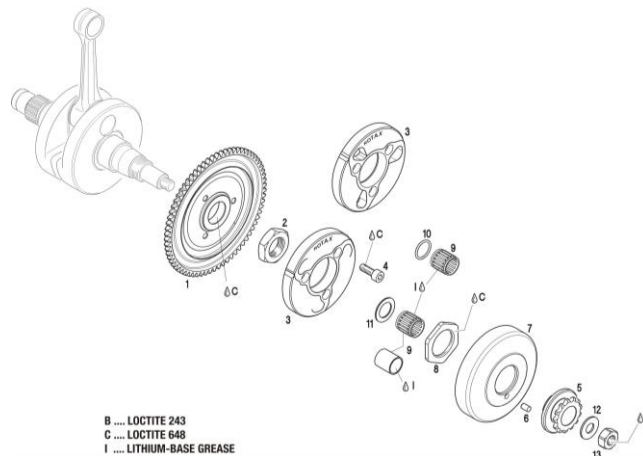

Only original Rotax clutch parts with Rotax logo are legal to be used.

Clutch must be mounted with bearing 15x19x17 (Rotax nr. 632415) including O-ring (Rotax nr. 950815)

In case of using engine sprocket 11-T the nylon plain bearing 15x17x17,6 (Rotax nr. 233855), including O-ring (Rotax nr. 950815) has to be used. To avoid any type of grease within the clutch we recommend to use not any grease!

Signs of emission of grease from the needle/plain bearing into the clutch drum may not exceed the picture below. Contact area between clutch and clutch drum has to be dry at any time. No lubrication allowed.



Clutch specifications at any time :

Height of the clutch : minimum 11,45mm



Thickness of the clutch shoe : minimum 24,10mm



Measurement has to be done at the 3 open ends of the clutch, 5 – 10mm from the machined groove (all clutch shoes must be completely closed at measurement – no gap)

Clutchdrum : (Rotax nr. 659930 and Rotax nr. 659937) are legal to be used.

The outer diameter of the clutch drum : minimum 98,50mm. Diameter has to be measured with a sliding caliper just beside the radius from the shoulder. (Not at the open end of the clutch drum).

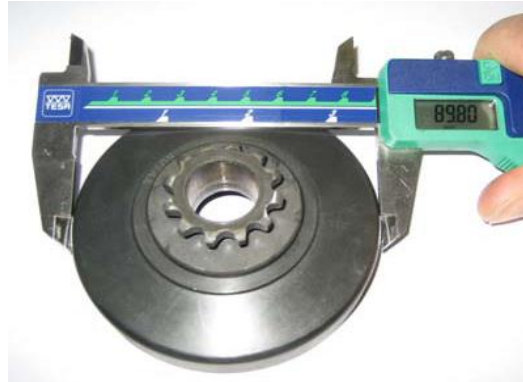

The inner diameter of the clutch drum : maximum 84,90mm. The inner diameter has to be measured with a sliding caliper. The measurement has to be done in the middle of the clutch drum (in the contact area between clutch and clutch drum).



The height of the clutch drum with sprocket : minimum 33,90mm



4.40 /
Intake silencer

Intake silencer with integrated, washable air filter has to be used with all parts. and has to be mounted on the support bracket with two screws (in dry and wet conditions).

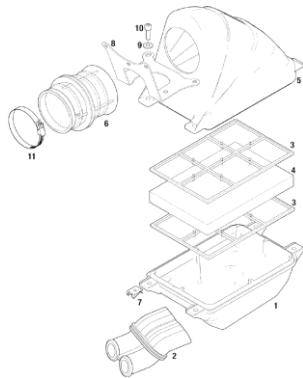

Intake silencer tube (pos2) and carburettor socket (pos 6) are marked with the wording "Rotax".

Intake silencer case bottom is marked on the inside with the Rotax part nr. 225015.

Intake silencer case, top is marked on the inside with the Rotax part nr. 225025

Two versions of original air filters (pos 4) are legal to be used.

Air filter (pos 4) must be installed as as shown in the illustration between the two holders (pos 3) and must cover the complete area of the intake silencer case bottom.



Using elements with the wording "Aprillia" is not allowed !

4.41 /
Exhaust system

Original exhaust system as supplied by Rotax is mandatory to be used.
Exhaust system, Rotax EVO (Rotax part nr. 273078) is mandatory.

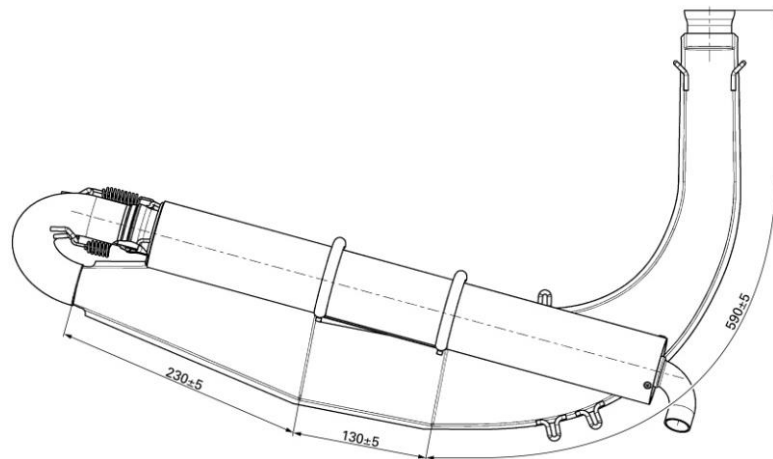

Turned pipe with 180° elbow and silencer are two separate pieces. The silencer is fixed with two springs to the 180° elbow and two springs to the tuned pipe. To fit a 3rd original spring (crosswise at the ball joint connection between 180° elbow and silencer) is an allowed option. The silencer has to be mounted in a position where the direction of the 90° elbow outlet (direction of the hot exhausts gasses) does not harm any component of the chassis. The original design silencer end cap with 90° elbow is mandatory to be used.

The original Rotax isolating mat (Rotax nr. 297981) is mandatory.

Replacing the perforated cover and isolating mat are legal to be replaced by original Rotax parts.

The isolating mat should cover the perforated cover at any time.

Replacing the original rivets of the silencer end cap by 4mm metric screws and corresponding locking nuts is an allowed modification.

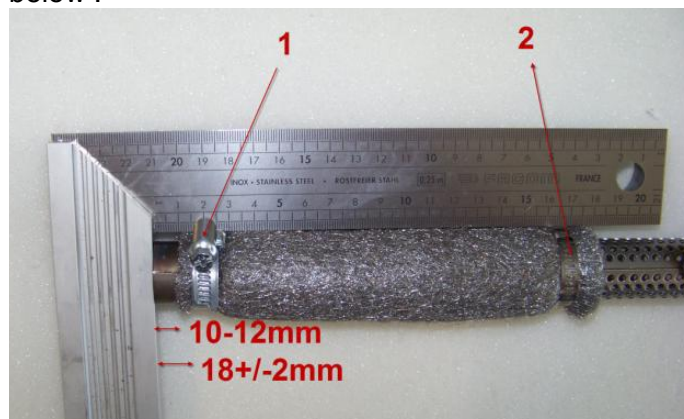

Additional to the standard isolation mat a steel isolation mat (Rotax part nr. 297983) of the square dimension of 165 (+10mm) is legal (not mandatory) to be assembled underneath the standard isolating mat according to the illustration below :



Clamp (1) must be fitted at a distance of 18 (+/-2mm), measured from the end of the tube.

Clamp (2) must be fitted at the end of the perforated tube to the beginning of the steel isolating mat is a specification for assembly purpose only.

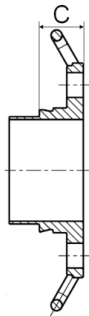
Both clamps (1 and 2) are mandatory to be fitted and tightened.

	<p>The exhaust system should be mounted to the chassis by using the two original mounting brackets. Rubber buffers are mandatory to be placed between the system and chassis.</p> <p>The use of maximum 4 pieces of original Rotax exhaust springs, to fix the exhaust system to the cylinder is allowed. Any other item is not allowed.</p> <p>Welding a socket on the top of the exhaust system for measuring the exhaust gas temperature is an allowed modification. Distance : 50-80mm from the ball joint.</p> <p>Welding at the exhaust system is only allowed in case of a repair. Modifications are not allowed.</p> <p>The organization reserves the right at all times to change exhaust systems from drivers with exhaust systems from the organization.</p>
Length of inlet cone	590mm +/- 5mm
Length of cylindrical part of exhaust pipe	130mm +/- 5mm
Length of cone	230mm +/- 5mm (measured outside)
Outside diameter 180° elbow pipe	Maximum Ø 41mm
Diameter hole end of tube	Maximum 22,5mm
Total length of exhaust pipe	Minimum 500mm +/- 1 mm
4.42 / Exhaust restrictor	<p>The measurement (C) must be at least 15,5mm Only restrictor Rotax.nr. 273190 including seal ring is legal to be used.</p>  
4.43 / Gear	<p>Rear sprocket type 219. Ratio is free. Engine sprocket 11t, 12t, 13t or 14t (marked with wording "Rotax")</p>
4.44 / Fuel test	<p>The organization has the reserves to test the race fuel at any time.</p>

<p>4.45 / Fuel</p>	<p>It is only allowed to use fuel with a maximum of 98 octane. Checks will be done with a Digatron DT-47FT fuel tester which is calibrated in pure liquid cyclohexane. If the value (result) of the check is higher than +60 the driver will be disqualified. Each race the organisation will recommend a fuel station. If fuel is changed by the organisation, the driver will receive, from the designated fuel station, 98 octane fuel that is mixed with 2% Denicol Syn 100.</p>
<p>4.46 / 2-stroke oil</p>	<p>It is not allowed to add any product to the fuel, except 2-stroke oil.</p>
<p>4.47 / NOTE</p>	<p>The dutch version of these regulations forms the basis in case of a dispute.</p>